

A) Spring and Diaphragm Actuator

B) PFE - 8, PFE - 10, PFE - 12

Segmented V-Ball Control Valve GAD

Valve Measurements* (Diagram B Below)

SIZE		A	A1	B	E	L	L1	H	F	d1	D	c	h	n	t	g	f
8"	mm	152	205	240	58	243	140	28	125	M12	343	298.5	22.3	8	29	270	1.5
	inch	5.98	8.07	9.45	2.28	9.56	5.51	1.102	4.92		13.5	11.75	.875	8	1.14	10.63	.06
10"	mm	192	259	276	58	297	176	28	125	M12	406	362	25.4	12	30.5	324	1.5
	inch	7.56	10.20	10.87	2.28	11.69	6.93	1.102	4.92		16.0	14.25	1.0	12	1.2	12.75	.06
12"	mm	225	300	302	64	338	207	36	140	M16	483	432	25.4	12	32	381	1.5
	inch	8.86	11.81	11.89	2.52	13.31	8.15	1.417	5.51		19.0	17.0	1.0	12	1.26	15.0	.06

*Specifications subject to change.

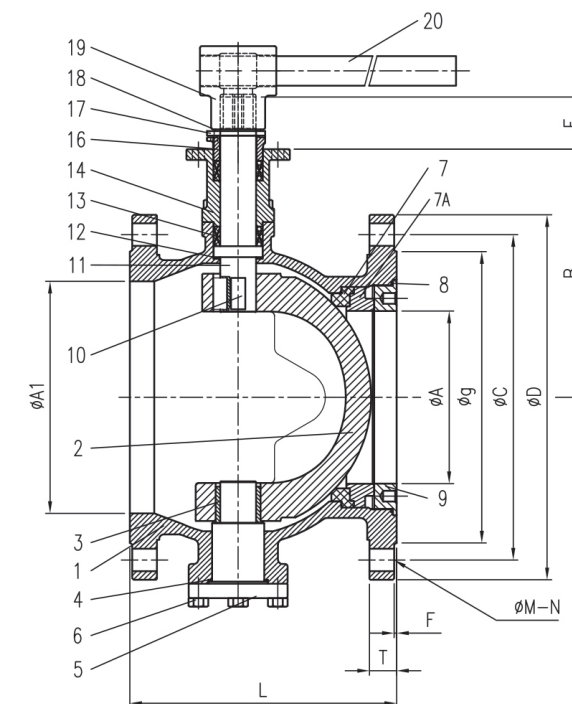
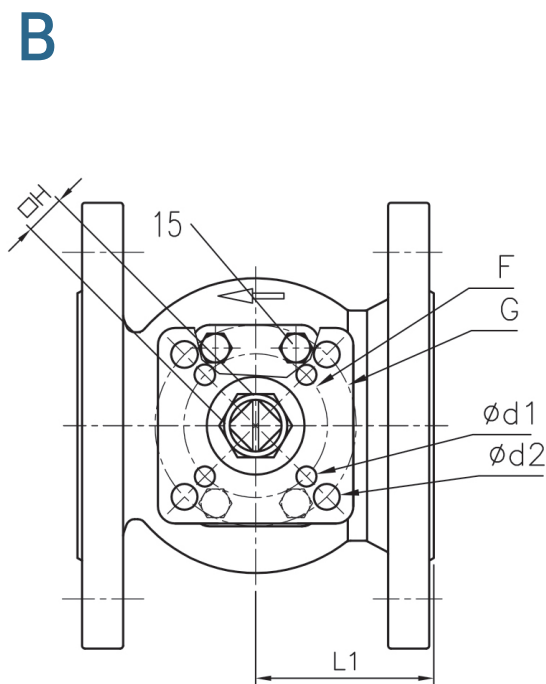
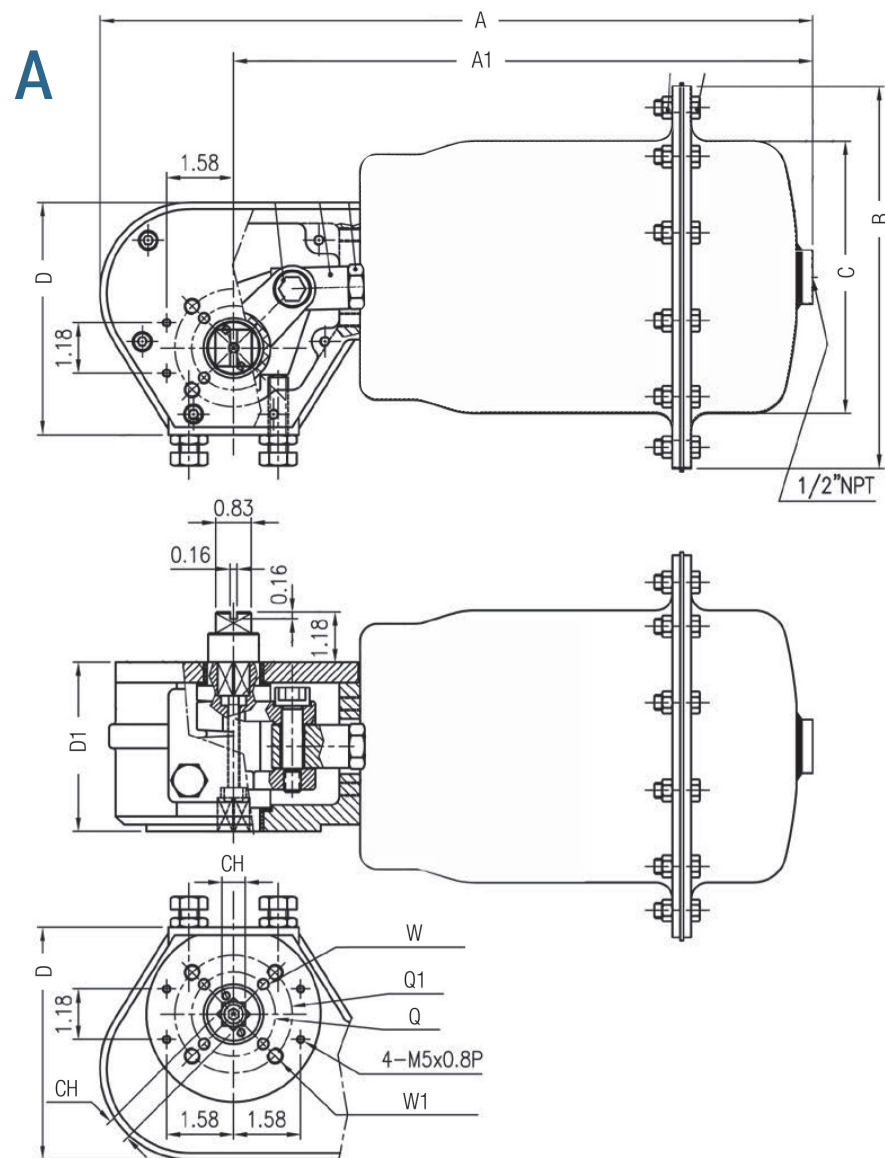

396 St. Croix Trail South, Suite 283
 Lakeland, MN 55043
 www.atlasairandwater.com
 sales@atlasairandwater.com
 Serving Industry Since 1986!