

PFE-2

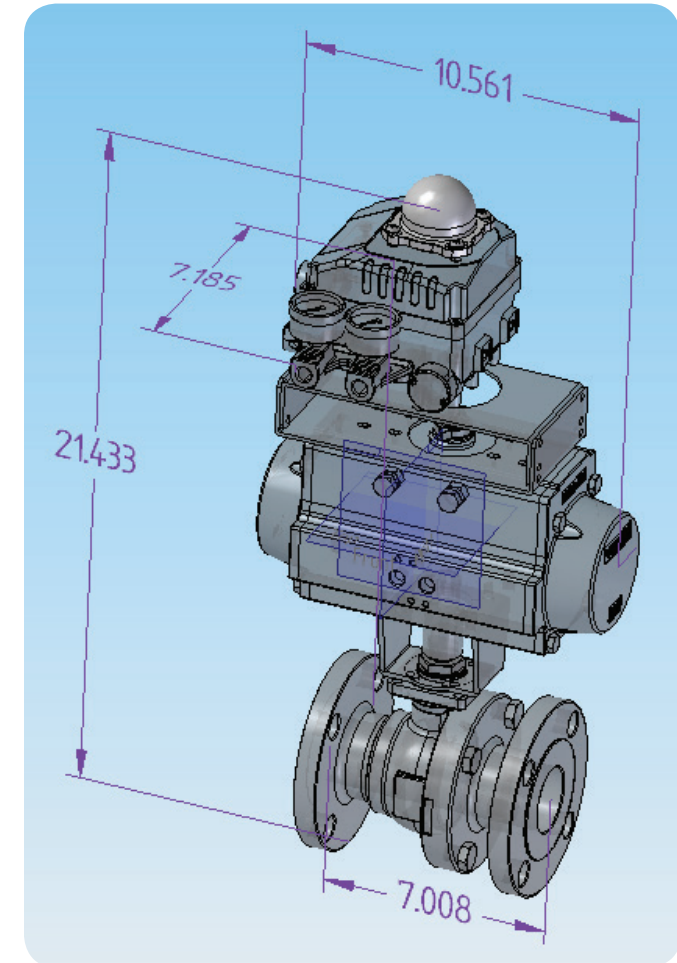
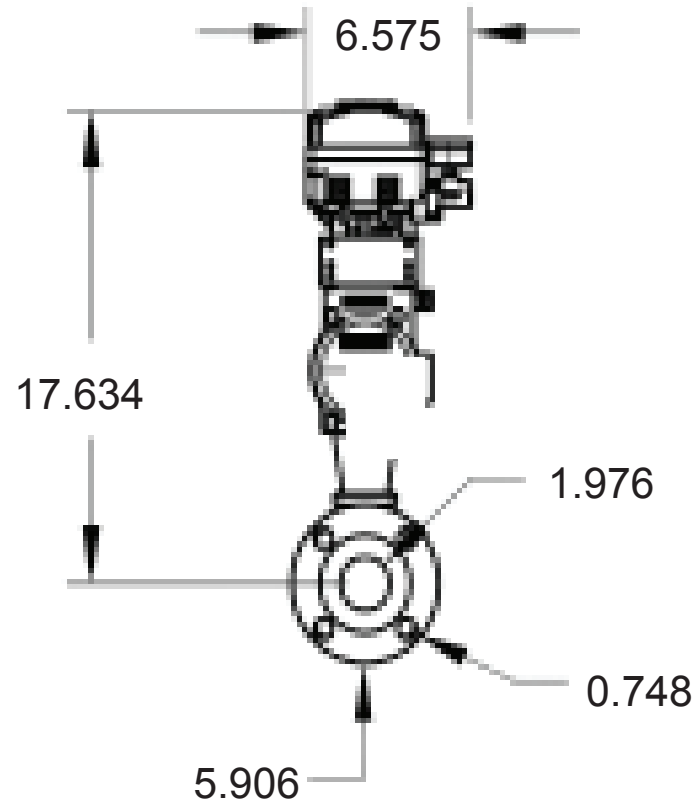
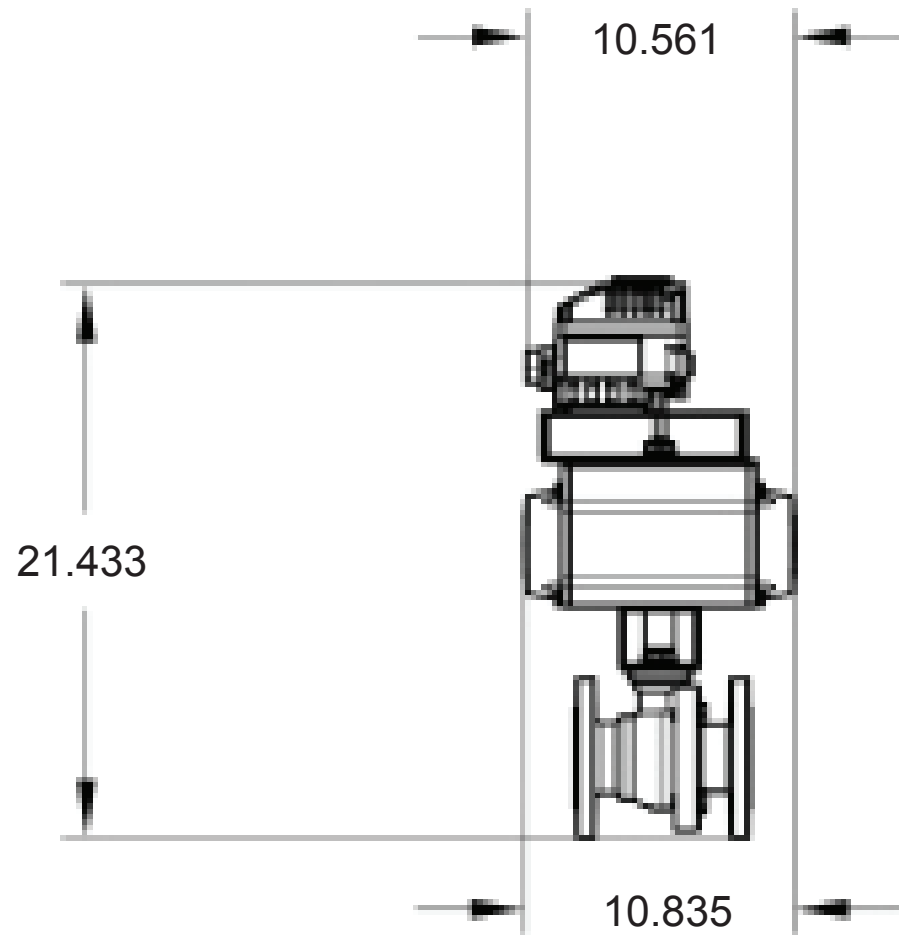
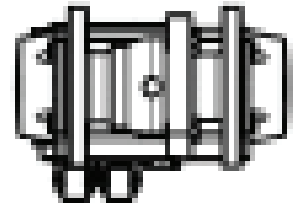

- NOTES:
- 1) Dimensions are for reference only.
 - 2) Max Operating Pressure: 250 psig
Operating Pressure range: 85-250 PSIG
Set Point Range: 40-225 psig
 - 3) PFE must be properly supported. Follow installation instructions
 - 4) Flow rating based on 110 psig inlet, 100 psig set point (outlet) and 68' F compressed air temperature. Flow rating will vary under different conditions.
 - 5) ASME B16.5 150# Flanges
 - 6) Compressed air supply must be clean, dry air.
 - 7) Bypass recommended but not provided. Bypass installed by others.
 - 8) Style of isolation valve (ball or butterfly) will vary depending on pipe size. Between isolation valves, on both sides of the PFE, a method to "bleed" the air line is required but not shown.

CONFIDENTIAL - This document is the property of Atlas Air & Water, Inc. and is not to be distributed outside the company.

Note	Position	Modified from	Date	Intr./Appd.
4				

All materials supplied are in compliance with the requirements of the List of Prohibited Substances

Tolerances if not indicated according to:			
+/- 1.0"			
Name	Confidentiality Class	Internal	
Material	ACD		
Treatment			
Scale	Family	A1	Compare
Drawn by	Corporate		Replaces
Version	Blank wt.	Kg	Designation
Drawn	Blank wt.	Kg	Designation
Released	Des checked.	Prod checked.	Approved
			Date 11/5/19

S.

G.